

ACCESSORIES PRODUCT CATALOG



**GLOBAL
FINISHING
SOLUTIONS**

TABLE OF CONTENTS

About GFS	3
Paint Booth Filters	4-7
Paint Booth Accessories.....	8-9
Controls & Air Balancing.....	10-11
Automated Door Systems.....	12
Paint Booth Doors	13-15
Curtain Walls & Dividers	16
Paint Booth Motors	17
Paint Booth Fans.....	18-20
Paint Booth Lighting	20 - 21
Paint Booth Ductwork.....	22-23
Paint Booth Electrical Components	24-25
Paint Booth Protection	26

ABOUT **GFS**

FULL-SERVICE PARTS & FILTERS DEPARTMENT

Headquartered in Osseo, Wisconsin, Global Finishing Solutions (GFS) has an extensive history of providing the aerospace, automotive refinish and industrial finishing industries with exceptional equipment and services, which helps businesses maximize productivity and achieve flawless finishes.

Dedicated to ensuring your GFS equipment continues to operate in peak condition for many years, we carry a complete line of high-quality replacement parts and accessories for all our products, including most legacy brands. Our experienced sales representatives will work with you to find the right part or product for your specific equipment. By stocking our most common parts and filters at GFS, we offer quick turnaround and fast shipping throughout North America and around the world.



CONTACTING GFS

PARTS & FILTERS SALES
parts@globalfinishing.com
fax: 888-338-4584
toll free: 800-848-8738

TECHNICAL SERVICES
techservices@globalfinishing.com
fax: 715-597-8818
phone: 715-597-8352

PAINT BOOTH FILTERS



GFS WAVE® PAINT BOOTH FILTERS

The most versatile single-stage paint booth exhaust filter, GFS Wave filters accommodate all coatings in a variety of spray applications – from clear coats to high solids paints.

With an exceptional removal efficiency rating of 99.94 percent, GFS Wave filters minimize particle emissions. In addition to protecting the environment, a clean exhaust air stream shields the paint booth's exhaust chamber, ductwork and fan from overspray accumulation.

The convoluted design of GFS Wave filters maximizes surface area for exceptional depth loading and holding capacity. By effectively capturing and retaining overspray, GFS Wave filters reduce runoff. This results in less cleanup on the floor of the paint booth and quicker, more efficient filter changes. GFS Wave paint booth filters meet NESHAP requirements. The material also complies with OSHA, NFPA 33 and UL 900 standards.

GFS Wave paint booth filters meet NESHAP requirements and comply with NFPA 33, OSHA and UL 900 standards.

WAVE Pads

Part No.	Size	Quantity per Box
FIL-EPP-2020-W	20" x 20"	30
FIL-EPP-2025-W	20" x 25"	30

WAVE Rolls

Part No.	Size	Quantity per Box
FIL-ERP-2030-W	20" x 30' roll	1
FIL-ERP-2430-W	24" x 30' roll	1
FIL-ERP-3024-W	30" x 24' roll	1
FIL-ERP-3030-W	30" x 30' roll	1
FIL-ERP-3050-W	30" x 50' roll	1
FIL-ERP-3630-W	36" x 30' roll	1
FIL-ERP-4030-W	40" x 30' roll	1
FIL-ERP-4530-W	45" x 30' roll	1
FIL-ERP-4548-W	45" x 48' roll	1
FIL-ERP-4830-W	48" x 30' roll	1
FIL-ERP-5430-W	54" x 30' roll	1
FIL-ERP-6030-W	60" x 30' roll	1
FIL-ERP-8020-W	80" x 20' roll	1

EXHAUST FILTERS

GOLD POLYESTER FILTERS

Gold polyester exhaust filters are made from multi-layered, multi-density polyester. Featuring high efficiency and excellent paint holding capacity, gold polyester filters are a cost-effective replacement filter media for any paint booth.



Part No.	Size	Quantity per Box
FIL-EPP-2020-G	20" x 20"	30
FIL-EPP-2025-G	20" x 25"	30
FIL-ERP-3050-G	30" x 50' roll	1
FIL-ERP-3650-G	36" x 50' roll	1
FIL-ERP-4550-G	45" x 50' roll	1
FIL-ERP-4850-G	48" x 50' roll	1
FIL-ERP-6050-G	60" x 50' roll	1

FIBERGLASS FILTERS

Fiberglass exhaust filters are exclusively designed to collect paint overspray. Made from continuous filament glass fibers with an open-weave pattern, the filters allow particles to penetrate deep into the 2-inch-thick pad and hold more paint. The filters are UL listed and Class II approved.



Part No.	Size	Quantity per Box
217-001	20" x 20"	100
217-002	20" x 25"	100
217-016	40" x 75' roll	1
217-017	30" x 75' roll	1
217-019	42" x 75' roll	1
217-020	24" x 75' roll	1
217-021	36" x 75' roll	1
217-022	48" x 75' roll	1
217-023	60" x 75' roll	1
217-024	72" x 75' roll	1
217-025	84" x 75' roll	1
217-029	42" x 300' roll	1
217-080	60" x 300' roll	1
217-088	48" x 300' roll	1
217-089	84" x 300' roll	1
217-095	36" x 300' roll	1
217-510	48" x 750' roll	1

PANEL FILTERS

Used to filter intake and exhaust air for GFS' ovens, panel filters are available in wood or metal frames. The filters are designed to capture overspray that was not retained by the exhaust filtration media, helping maintain a cleaner environment and avoid overspray in exhaust fan blades.



Part No.	Size	Quantity per Box
217-516	24" x 24" x 12" (Wood Frame)	1
217-518	24" x 24" x 12" (Metal Frame)	1

PAINT BOOTH FILTERS

EXHAUST FILTERS

HIGH-PERFORMANCE POLYESTER MEDIA

High-performance polyester media is designed for capturing overspray of paint, glue, resin, tar, teflon, oil, grease and other airborne liquid particles. Made from 1-inch-thick, multi-layered, multi-density polyester, it features high-capacity capture with high-efficiency air pollution control. The media is UL listed, Class II approved and meets OSHA requirements.



Part No.	Size	Quantity per Box
217-006	20" x 20"	30
217-041	24" x 24"	25
216-532	72" x 2" x 50' roll	1
216-538	30" x 2" x 50' roll	1
216-561	24" x 50' roll	1
216-562	48" x 50' roll	1
216-563	36" x 75' roll	1
216-564	48" x 75' roll	1
216-565	60" x 75' roll	1

INTAKE FILTERS

INTAKE PADS

Intake pads are a high-efficiency mesh intake filter that removes more than 90 percent of particles at 5 microns. They feature an internally welded steel frame for easy fit, and a self-sealing gasket. Internal wire support and heat-sealed seams prevent media flutter. The pads are UL listed and Class II approved.

Part No.	Size	Quantity per Box
216-550	20" x 20" x 1" (Diffusion)	24
216-551	24" x 24" x 1" (Diffusion)	24
217-010	16" x 20" x 1" (Tacky)	24
217-011	16" x 25" x 1" (Diffusion)	24
217-012	20" x 20" x 1" (Tacky)	24
217-012-Green	20" x 20" x 1" (Tacky, Green)	24
217-013	20" x 25" x 1" (Tacky)	24
217-014	24" x 24" x 1" (Tacky, Rigid Metal Frame)	24
217-200	20" x 48" x 2"	8
PF-1000	20" x 48" (Micro Clean)	12
PF-2000	20" x 48" (Micro Clean)	15

TACKY ROLL MEDIA

Made from synthetic fibers and resin-bonded with a special adhesive, tacky roll media intake filters are a progressively structured, high-performance media. The pads feature an internally welded steel frame for easy fit, and a self-sealing gasket. The filters are self-extinguishing, with a 100 percent coating of fibers. Tacky roll media is UL listed and Class II approved.

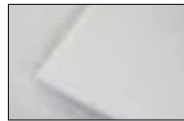

Part No.	Size	Quantity per Box
216-234	55" x 96"	2 rolls
216-237	55" x 120"	2 rolls
216-528	50" x 90"	1 roll (ME1 Polyester Media)
216-531	50" x 30"	1 roll (ME1 Polyester Media)

INTAKE FILTERS

HIGH TEMPERATURE ROLL MEDIA

High temperature roll media is designed for use with SmartCure® control systems, which generate higher heat during cure cycles. Filter material can withstand operating temperatures up to 220 degrees Fahrenheit. Its polyester fiber is bonded with a polyvinyl chloride binder, featuring a flame-retardant treatment.



Part No.	Size	Quantity per Box
FMI-CUSTOM	By the square foot	
FMI21036	21" x 36"	2
FMI21069	21" x 69"	2
FMI21072	21" x 72"	1
FMI21105	21" x 105"	2
FMI21141	21" x 141"	2
FMI21144	21" x 144"	2
FMI37036	37 1/2" x 36"	2
FMI37144	37 1/2" x 144"	2
FMI38062	38" x 62"	1
FMI51097	51" x 97"	1
FMI51108	51" x 108"	1
FMI51121	51" x 121"	2
FMI61120	61" x 120"	2
FMI61149	61" x 149"	2
FMI64108	64" x 108"	2
FMI64120	64" x 120"	2
FMI64144	64" x 144"	2
FMI64149	64" x 149"	2
FMI69097	69" x 97"	1
FMI69121	69" x 121"	1
FMI75030	75" x 30"	2
FMI75036	75" x 36"	2
FMI73069	73" x 69"	1
FMI73105	73" x 105"	1
FMI73141	73" x 141"	1
FMI69121	69" x 121"	1
FMI75036	75" x 36"	2
FMI75090	75" x 90"	2
FMI75120	75" x 120"	2
FMI75144	75" x 144"	2
FMI75149	75" x 149"	1
FMI78246	78 3/4" x 246"	1
FMI81036	81" x 36"	2
FMI81072	81" x 72"	1
FMI81108	81" x 108"	1
FMI81144	81" x 144"	1

PAINT BOOTH FILTERS

INTAKE FILTERS

ADVANCECURE® FILTERS

GFS' AdvanceCure Accelerated Airflow System requires its own filters, since the air intake is sized differently than other systems. These filters ensure clean air escapes the AdvanceCure System for a fast cure and a high-quality paint finish. The filters are made of high-loft, non-woven, expanded polyester, featuring a 99.84 percent average arrestance. AdvanceCure filters are UL listed and Class II approved.

Part No.	Size	Quantity per Box
ADV-4MW-FMI1116	10.875" x 16.25"	10
FMI-ACCT0811	10.5" x 7.75" (Corner Module, No Lights)	10
FMI-ACCT2671	13" x 9.5" (Corner Module, with Lights)	10
FMI-AC41811	15.25" x 24.25" (Corner Module)	10
FMI-WBTA2362	17" x 7.5" x 5.25"	10
FMI-AC1515	14.625" x 14.626"	10
FMI-ACCT1637	15.5" x 36.625"	2

PAPER FILTERS

PAPER MESH FILTERS

Paper mesh filters are combination baffle/strainer-type overspray collectors, constructed of layers of slit and UL listed, Class II approved kraft media. The front layers employ larger baffle openings, followed by layers of progressively smaller diamond designs and an optional back layer of dense, non-woven polyester.



Part No.	Size	Quantity per Box
216-088	20" x 20" x 1"	60
216-089	20" x 25" x 1"	70
216-095	42" x 2" x 30'	1

PLEATED CARDBOARD

Pleated cardboard is an accordion-style, collapsible paper filter with round holes that traps overspray. Overspray-laden air is drawn into the filter by the booth's fan and makes several radical directional changes as it's forced through the trapping chambers of the filter. Kinetic energy generated by each change in air direction causes individual paint particles to be deposited on the surfaces within the filter.



Part No.	Size	Quantity per Box
PEF-330-K1	3' x 30'	1, 3 or 60

PAPER FILTERS

PAPER MESH POLYESTER BACKING

Paper mesh polyester backing filters are highly efficient with an excellent dust-holding capacity. Constructed of seven-layer expanded paper, these filters feature a white polyester backing to maximize strength and efficiency.



Part No.	Size	Quantity per Box
EF-2020-K40	20" x 20" x 2"	40
EF-2025-K40	20" x 25" pad	40
EF-3125-K2	31" x 25' roll	2
EF-4253-K1	42" x 53' roll	1

THREE-STAGE FILTRATION FOR AEROSPACE CHROMATE COATINGS

GFS' high-efficiency, three-stage filtration system delivers a higher holding capacity and more cost savings than other systems. It is highly effective at capturing large volumes of paint, with up to 99.9 percent filter efficiency at 5 microns. The system is used for aerospace chromate coatings and meets NESHAP requirements.



STAGE 1 - CPA - PAINT ARRESTOR ROLL MEDIA

Part No.	Size	Quantity per Box
216-502	36" x 50'	1
216-503	45" x 50'	1
216-512	50" x 50'	1
216-532	72" x 50'	1
216-539	45" x 75'	1
216-535	72" x 75'	1
216-541	102" x 75'	1
216-543	120" x 50'	1
216-547	54" x 75'	1
216-564	48" x 75'	1
216-565	60" x 75'	1

STAGE 2 - MEPT PANEL FILTER

Part No.	Size	Quantity per Box
216-501	20" x 20"	24
216-517	24" x 24"	24
215-044	20" x 20"	24

STAGE 3 - POCKET BAG FILTER

Part No.	Size	Quantity per Box
216-500	20" x 20" x 15" (2 Pocket)	1
216-505	20" x 20" x 12" (6 Pocket)	1
216-516	24" x 24" x 12" (6 Pocket)	1
216-061	20" x 20" x 12" (6 Pocket)	1

PAINT BOOTH FILTERS

3-STAGE FILTRATION FOR OLDER POWDER & DUST NON-RECOVERY BOOTHS



STAGE 1 - WAVE ROLL MEDIA

Part No.	Size	Quantity per Box
FIL-ERP-3630-W	36" x 30'	1
FIL-ERP-4530-W	45" x 30'	1
FIL-ERP-4830-W	48" x 30'	1
FIL-ERP-5430-W	54" x 30'	1
FIL-ERP-4548-W	45" x 48'	1
FIL-ERP-3050-W	30" x 50'	1

STAGE 2 - MEPT PANEL FILTER

Part No.	Size	Quantity per Box
216-501	20" x 20"	24
216-517	24" x 24"	24
215-044	20" x 20"	24

STAGE 3 - POCKET BAG FILTER

Part No.	Size	Quantity per Box
216-500	20" x 20" x 15" (2 Pocket)	1
216-505	20" x 20" x 12" (6 Pocket)	1
216-516	24" x 24" x 12" (6 Pocket)	1
216-061	20" x 20" x 12" (6 Pocket)	1

POWDER & DUST NON-RECOVERY BOOTH FILTERS



PRIMARY FILTERS

Wave - Roll Media

Part No.	Size	Quantity per Box
FIL-ERP-3630-W	36" x 30'	1
FIL-ERP-4530-W	45" x 30'	1
FIL-ERP-4830-W	48" x 30'	1
FIL-ERP-5430-W	54" x 30'	1
FIL-ERP-4548-W	45" x 48'	1
FIL-ERP-3050-W	30" x 50'	1

Panel Filter

Part No.	Size	Quantity per Box
216-511	20" x 20" x 4"	6

REDUNDANT FILTER

Part No.	Size	Quantity per Box
216-038	24" x 24" x 12"	1

POWDER & DUST FILTERS

FILTER PADS

Medium-efficiency, pleated panel filters for powder and dust collection are made of a non-woven cotton/synthetic blend media. They feature radial pleat construction, allowing for minimum pressure. Filter pads are UL and CUL listed, and Class I and Class II approved.

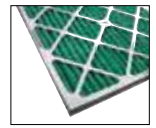

Part No.	Size	Quantity per Box
216-003	20" x 20" x 4"	6
216-011	20" x 20" x 2"	1
216-013	20" x 25" x 2"	1
216-511	20" x 20" x 4"	6

CARTRIDGE FILTERS

High-efficiency cartridge filters are used to collect powder overspray in powder recovery booths and dust in dust collection systems. These high-strength filters feature a flame-retardant treatment.



Part No.	Size	Quantity per Box
216-202	26" x 12 3/4"	1
216-203	26" x 12 3/4"	1
216-204	26" x 12 3/4"	1
216-208	52" x 12 3/4"	1

AIR MAKE-UP UNIT (AMU) FILTERS

AMU filters clean the air entering an air make-up unit, which provide an economical source of replacement air.



Part No.	Size	Quantity per Box
33033	24" x 24" x 2"	4
405213	23 1/4" x 47" x 9" (6 Pocket)	4
405214	23 1/2" x 47" (Framed 5 Pocket)	4
405216	19 1/4" x 37" x 4" (High Capacity)	4
405217	19 3/4" x 37" x 4" (High Capacity)	4
405219	19 1/2" x 36 3/4" (6 Pocket)	4
FMP2336	23 1/2" x 35 5/8" (4 Pocket)	4

FILTER COMPONENTS

Part No.	Description
217-003	20" x 20" Filter Grid, tips not included
217-004	20" x 25" Filter Grid, tips not included
248-016	Rubber Tips for Filter Grids
FHG8-0480	Filter Hook, 48" Sections
JSG8-0480	J-Strip, 48" Sections



GFS EXCLUSIVE PAINT BOOTH ACCESSORIES

PAINT BOOTH GRATING

GFS' heavy-duty steel grating allows the painter to safely walk on top of the pit. We offer replacement grating for all downdraft paint booths, and will work with you to find the right grating replacement for your booth or other finishing equipment.



AUTO REFINISH GRATING

Part No.
GRT-36031-150 Grating for GFS auto refinish paint booths is light-duty grating, measuring 1.5 inches thick. The grating comes with filter retainers.

GRATE LIFTING TOOL

Replacing exhaust filters in a downdraft paint booth is easy with GFS' exclusive grate lifting tool. This handy tool does the heavy lifting for you, picking up exhaust pit grates so you can quickly change filters without straining your back or pinching your fingers between grates. Made from sturdy metal, GFS' grate lifting tool can hold a maximum weight load of 260 pounds.



Part No.
GRT-TOOL

PAINT BOOTH PARTS HANGER SYSTEM

The flexible paint booth parts hanger system from GFS enables you to maximize productivity in your paint booth. Sturdy construction ensures parts stay put for easy spraying, and adjustable racks make positioning parts a snap. The standard parts hanger system comes with one support beam and two J-Hooks.



Part No.	Size
PH-CS-1014-Kit	10' x 14' (Ultra® Booths)
PH-FS-1010-Kit	10' x 10' (Performer® Booths)

DELUXE PARTS HANGER SYSTEM

- Comes with two support beams, two J-Hooks, one single track and two adjustable clamp and rod assemblies
- Allows parts hanger system to move around the paint booth for added flexibility

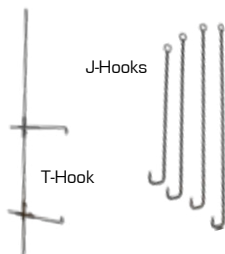

Part No.	Size
PH-CD-1014-Kit	10' x 14' (Ultra® Booths)
PH-FD-1010-Kit	10' x 10' (Performer® Booths)

MAGAHOOK™

The Magahook holds a variety of objects to metal surfaces, such as paint booth walls, parts caddies, lockers, toolboxes, warehouse racking and more.



Part No.	Size	Pull
218-014	Base: 2.65" Shaft: 3"	65 lbs
218-015 (U Style, with Soft-Coated Hook)	Base: 2.65"	65 lbs

ROTATING BOOTH ACCESS TABLE

Easily access premixed paint and other supplies from inside your paint booth with a rotating turntable that connects to your mix room. A technician can be mixing paint or preparing supplies at the same time another technician is spraying, increasing productivity and throughput, while keeping your booth free of clutter and debris.



Part No.	Size
RS-SPA36108	Dual-Skin Panel
RS-SPA2420	Single-Skin Retrofit Panel

BOOTHBOX 2™

The BoothBox 2 is a magnetic, double-compartment cabinet and double spray gun holder, designed for the interior of paint booths. With the BoothBox 2, you can store commonly used supplies – tape, gloves, tack cloth – within arm's reach, enabling you to increase productivity while eliminating time-consuming trips in and out of the booth.



Part No.	Size	Shipping Weight
218-002	15" x 14" x 6 1/2"	14 lbs

GFS EXCLUSIVE PAINT BOOTH ACCESSORIES

BOOTHBOX MINI™

The BoothBox Mini is a magnetic, single-compartment cabinet and double spray gun holder, designed for the interior of paint booths. With the BoothBox Mini, you can keep commonly used supplies – tape, gloves, tack cloth – close at hand, enabling you to increase productivity while eliminating time-consuming trips in and out of the booth.



Part No.	Size	Shipping Weight
218-006	14" x 7 1/4" x 6"	9 lbs

4 GUNHANGER™

The 4 GunHanger is a magnetic, four-position spray gun holder for paint booths, prep areas or mix rooms. The 4 GunHanger is also equipped with a hook for storing spray guns, tape and other supplies, allowing you to avoid clutter and keep objects off the floor.



Part No.	Size	Shipping Weight
218-011	7 1/2" x 18 3/4" x 7"	7 lbs

BOOTH SHELF WM™

The Booth Shelf WM is a combination of a magnetic, three-position spray gun holder and a vented working shelf. It can be used in a paint booth, prep area or mix room to hold spray guns, tape, tack cloth and other supplies.



Part No.	Size	Shipping Weight
218-009	14" x 10" x 8 1/2"	8 lbs

SINGLE GUNHANGER™

The Single GunHanger is a magnetic spray gun holder designed to hold all types of spray guns and most types of air tools. A soft edge guard eliminates scratching of the spray gun or gun cup.



Part No.	Size	Shipping Weight
218-004	3" x 5"	2 lbs

PUMP BOTTLE HOLDER™

The Pump Bottle Holder is a double magnetic hook, sized for common degreaser bottles. This accessory is designed for paint booths or prep areas so that bottles are easily accessible, as well as for hanging spray guns and pneumatic tools.



Part No.	Size	Shipping Weight
218-032	3.5" x 6" x 2"	1 lb

HOSE & GUNHANGER™

The Hose & GunHanger is a double spray gun holder and air hose hanger, designed for paint booths, prep areas or mix rooms. It comes equipped with a hook for storing tape and other supplies.



Part No.	Size	Shipping Weight
218-013	7 1/2" x 18 3/4" x 7"	7 lbs

MIRROR HANGER™

The Mirror Hanger is a two-part system for holding all sizes of mirrors and other parts for painting, eliminating the need to hang wires in a paint booth. Just attach the mirror to the holding handle, lift the handle from the powerful, magnetic base and spray; then place the handle back on the base while your paint dries.



Part No.	Size	Shipping Weight
218-033	3.5" x 6.5" x 21"	4 lbs

TEST PANEL HOLDER™

Simplify your test panel process with the Test Panel Holder. Simply attach paper or metal test panels, then hold and spray. For flash and dry times or everyday storage, place the magnetic Test Panel Holder on the wall of a paint booth – or other sheet metal surface.



Part No.	Size	Shipping Weight
218-023	6" x 4" x 17.5"	1 lb
218-024	1.5" x 1.5" x 17.5"	1 lb

CONTROLS & AIR BALANCING

CONTROLS

All control panels are UL 508 and CUL listed. Standard control panels feature single-point connection for quick and easy wiring with a NEMA-rated enclosure.

STANDARD CONTROL PANEL

Standard control panels feature a single-point connection for quick and easy wiring. They come in a NEMA-rated enclosure.



DELUXE CONTROL PANEL

Deluxe control panels are designed for special applications, such as booths with air make-up units (AMUs), multiple booth operations or booths with automatic air balancing systems.

Each deluxe control panel is designed for a single-point wiring connection and includes a terminal strip for field wiring. All wires are numbered for easy wire identification, and all components are labeled to match electrical schematics.



INSIGHT CONTROL PANEL

A PLC-based, UL listed control system with an intuitive, simplistic touch screen, the INSIGHT control panel allows you to continually monitor all systems for safety and function. Pop-up displays indicate running information and faults.



PROVEN CONTROL PANEL

Available on GFS Batch and Continuous Process Ovens, the Proven control panel features temperature and speed controls, troubleshooting capabilities and a user-friendly interface. The Proven control panel uses an Allen-Bradley PLC and HMI. All of the selections you need – cycle time, oven temperature, fan speed and alarms – are visible on the home screen, enabling continuous monitoring of all systems for safety and function.



ENGAGE® CONTROL PANEL

The Engage control panel features a simplified, easy-to-use interface with enhancements such as improved temperature and pressure control, and alarm tracking for better, more reliable booth performance.



LOGIC 3 CONTROL PANEL

An impressive yet simple control system, the LOGIC 3 control panel is designed with everything you need to control your paint booth. It comes standard with controls for optional AdvanceCure®, SmartCure® and Smart Flash and can be upgraded to include Filter Monitoring and Economy Mode functions with the purchase of an intake variable frequency drive (VFD). The panel is easy to use with a 6-inch monochrome interface that provides all the information you need.



LOGIC 4 CONTROL PANEL

The fully loaded LOGIC 4 control panel provides complete control over your booth, with the ability to easily switch from a waterborne user interface to a solvent-based interface. At the touch of a button, you have controls for AdvanceCure®, SmartCure® and Smart Flash. The panel even comes with Filter Monitoring and Economy Mode functions, saving you time and money. The LOGIC 4 boasts a 10-inch color user interface, providing ease of use and displaying more information on each screen so users can operate the booth quicker and more efficiently.



VELOCITY® CONTROL PANEL

The Velocity control panel combines the function of a fully integrated control system with a user-friendly interface and budget-friendly price tag. Enhanced troubleshooting capabilities, several booth modes and Auto-Balance come standard on the new Velocity control panel.



CONTROLS & AIR BALANCING

AIR BALANCING

The following air balancing packages can be purchased with new paint booths or for existing booths. The packages can be purchased alone or in tandem for additional energy savings.

VARIABLE FREQUENCY DRIVE (VFD)

VFDs automatically adjust fan motor speeds based on actual airflow conditions and maintain an air balance within the paint booth, preventing paint fumes from escaping and dust from entering. VFDs also provide optimum air pressure, consistent exhaust and consistent temperature.



Benefits:

- Decreased energy cost
- Improved process control
- Increased transfer efficiency
- Controlled overspray directly into filtration systems
- Controlled, exhausted VOCs from the workplace
- Extended dry filter usage, up to 50 percent
- Cleaner system and paint finishes

POWER SAVER (For Non-Pressurized Paint Booths)

Power Saver is a control panel upgrade that allows the painter to slow the exhaust fan to half speed when not painting. Included is a variable frequency drive (VFD), which controls the fan motor and a gun hanger switch. When the painter hangs the spray gun on the hook, the VFD will slow the fan to half speed. When the paint gun is taken off the hook, the fan returns to full speed.



Energy is conserved in two ways:

- Fan motor uses less electricity
- Booth exhausts less heated air during cold months

The Power Saver upgrade reduces airflow by 50 percent during energy-saving mode.

Note: In cases where an Air Make-Up Unit (AMU) accompanies a non-pressurized paint booth, Power Saver will control only the paint booth.

CONSTA-FLOW (For Non-Pressurized Paint Booths)

The Consta-Flow System is designed to automatically adjust the exhaust fan to the changing conditions of the exhaust filters. GFS recommends Consta-Flow for all paint booths with conveyor openings and booths with multiple filter stages that have high static pressure when loading.



Consta-Flow consists of a variable frequency drive (VFD) that controls the exhaust fan motor, a differential pressure gauge and sensing probes. The system monitors static pressure and adjusts the exhaust fan's RPMs to what's needed for the volume of exhaust air, based on how loaded the filters are. The result is a booth with constant airflow as filters load up with paint, increasing filter life.

ECONOMIZER (For Pressurized Paint Booths)

Economizer is a control panel upgrade for booths that have air make-up units (AMUs) directly pressurizing the booth. The upgrade includes an Auto Balance System, variable frequency drive (VFD) and gun hanger switch. The VFD automatically adjusts the airflow of the exhaust fan(s) to ensure proper booth balance.



The gun hanger switch, located inside the paint booth, controls the booth function from paint mode to energy-saving mode. When the paint gun is hanging on the hook, the booth airflow slows to half speed. When the paint gun is removed from the hook, airflow resumes to full speed.

The Economizer reduces airflow by 50 percent during energy-saving mode.

Economizer can only be used on new or existing paint booths with variable air volume air make-up units (AMUs). A control panel purchased with Economizer also automatically receives an Auto Balance System, which keeps the booth balanced regardless of filter loading.

AUTO BALANCE (For Pressurized Paint Booths)

Recommended for all pressurized booths, Auto Balance is designed to keep the paint booth balanced while in operation. The system consists of a variable frequency drive (VFD) that controls the exhaust fan motor, a differential pressure gauge and sensing probes.



The Auto Balance System monitors interior booth pressure, adjusting the exhaust fan's RPMs to what's needed for the volume of exhaust air, based on what the incoming intake air is. The result is a booth that's balanced automatically and stays in balance as filters load up with paint overspray. The system increases useful filter life, provides a constant airflow throughout the booth and allows you to easily control the booth pressure.

ROLLSEAL® AUTOMATED DOOR SYSTEMS

AN EXCELLENT SEAL AT AN AFFORDABLE PRICE

Exclusive to Global Finishing Solutions paint booths and finishing equipment, RollSeal Automated Doors eliminate the space needed for traditional swing or wing-style doors. RollSeal Doors are durable and low maintenance, providing an excellent seal at an affordable price.

With a unique, patented design, RollSeal's triple-layered fabric door and airtight seal prevent overspray from escaping the booth and keep contaminants out of your paint jobs. RollSeal Doors operate at the press of a button, with the ability to adjust door operation speeds. Air is not disturbed during operation, keeping dirt and dust out of the booth.

EASY INSTALLATION

All RollSeal Doors come complete with heavy-duty mounting tracks and a horizontal header with the roll-up door pre-installed. The door system can be easily installed at the entrance or exit of your booth. Simply assemble the tracks and header, attach the frame to the booth and mount the controller. RollSeal Doors require less structural support than metal roll-up doors and have minimal failure points to decrease maintenance.

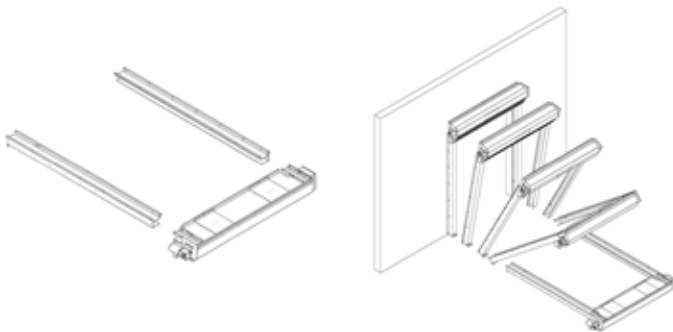

HIGH-QUALITY CONSTRUCTION

RollSeal's triple-layered fabric with air between layers helps maintain the desired heat levels inside the booth, meeting cure temperature requirements. With fewer moving parts than traditional roll-up doors, less time and money is spent replacing rollers, tracks, panels and hinges. RollSeal's fabric doors are impact resistant; however, if they are punctured or damaged, they can be easily repaired or replaced at a fraction of the cost of a metal roll-up door.



CUSTOMIZED SOLUTIONS

RollSeal can custom design a door using your parameters and drawings, providing a solution for openings up to 24 feet wide and 24 feet high. In addition to product entrance and exit, RollSeal Doors can be used in Side-Load Systems to control contamination and airflow between bays.



PAINT BOOTH DOORS

PRODUCT DOORS

Product doors are constructed of tubular frames and sheet metal, and are factory painted. Filters, door handles, door safety latches and foam tape are included.

Product Entrance Doors						
	Face Mount	Flange Mount	Width	Height	Galvanized	Precoat White
Solid Swing	IPDS	IPDS2	A	B	G	W
Solid Bi-Fold	Contact GFS	IPDS4				
Filtered Swing	IPDF	IPDF2				
Filtered Bi-Fold	Contact GFS	IPDF4				

Note:

- Indicate Width (A) and Height (B) when ordering.
- Tri-Fold/Multi-Wing Doors are also available, please contact GFS.

SOLID DOORS

Solid doors are used with pressurized input plenums to enclose open front paint booths in pressurized applications. The door size is 2 feet shorter than the booth's interior height and 4 feet narrower than the booth's interior width.

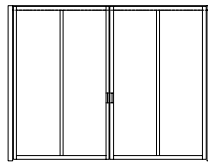

ROLL-UP DOORS

Roll-up doors are manufactured per GFS' specifications. The finished product is delivered directly to the job site by the manufacturer – to be installed, adjusted and serviced by trained factory personnel.

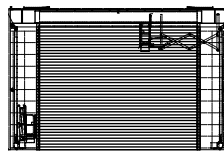

Roll-up doors are available in galvanized stainless steel and aluminum. Finishes range from 21 standard colors to 172 premium colors, or color-matched to customer specifications, as well as colored, anodized aluminum.

FILTER DOORS

Filter doors allow product entry and exit in non-pressurized booths, while filtering input air. The doors attach directly to the front of the booth, adding minimal depth to the booth.

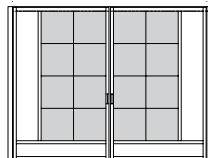

Product Entrance Doors

Part No.	Description
FFC234	Frame crate 2 slab - filtered door
FFC333	3 slab solid door used with a yoke
FFC344	3-wing frontal
FFC401	Frame crate 4-wing frontal
FRC212	Frontal crate - filtered door
FRC332	Frontal crate 3 slabs no side panels
FRC411	Frontal crate 4 slabs, with two 18" side panels
FRC41109	4-wing frontal 4 slabs, no side panels

PERSONNEL DOORS

3-by-7-foot universal personnel access doors are constructed of 18-gauge galvanized sheet steel. The door can be located on either side of the booth and can be installed for a right- or left-hand swing to meet user requirements. Options include an 18-by-24-inch observation window and pre-coated white. Includes an installation kit.



Part No.	Size	Description
MDUG-36084	36" x 84"	Galvanized
MDUG-36084-OSQ	36" x 84"	Galvanized, with Observation Window
MDUW-36084	36" x 84"	White Pre-Coated
MDUW-36084-OSQ	36" x 84"	White Pre-Coated, with Observation Window

OBSERVATION WINDOWS

Observation windows are designed for applications with booth panels and for use with solid product doors. Featuring clear, tempered glass, observation windows are an attractive option for monitoring personnel safety, with a safe, unobstructed view of painting operations.

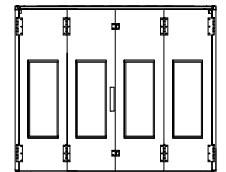

Part No.	Size	Description
WK-1824-MANDOOOR	18" x 24"	Galvanized (Personnel door)
WK-1824-MANDOOOR-WH	18" x 24"	White Pre-Coated (Dual-skin personnel door)

Panel kit includes tempered glass and weather stripping

Part No.	Size	Description
WK-1824	18" x 24"	24" Observation Window
WK-1848	18" x 48"	48" Observation Window

PAINT BOOTH DOORS

HARDWARE

GFS uses only top-quality hardware. Our weld-free designs mean no weak points and no corrosion. GFS hinges, latches and hardware are all fully adjustable so you get the perfect fit, every time.

DOOR HINGES





Part No.	Description	
208-242	Strap, 16" long, Zinc Flush	
208-033	Steel 1.75" wide x 8" long, Butt	
208-411	Burn-Off Oven, 11" long	
208-029	4" x 10" x .125" Steel Butt Style	
208-030	2.5" x 10" x .125" Half Swaged	
208-119	2.5" x 4" x .125" Partly Swaged	
DHA04110-A	Automotive, Assy Open	
DHA05111-A	Automotive, Assy Closed	
DHA04110-G	Industrial, Assy, E-dip	
KHDC-2000	Automotive, Hinge Kit Center Door, Blowtherm (System 2000)	
KHDS-2000	Automotive Door Hinge Kit, Blowtherm (System 2000)	



DOOR LATCHES

Part No.	Description	
208-037	BRIXON #83P Cast Steel	
208-094	BRIXON #2P Cast Iron	
LTC235	Door Clicker (Each)	
STR1535	Striker Plate Long (Frontal Doors)	
STR735	Striker Plate Short (Personnel Door)	
208-085	Lever Latch with Pins & Clips	
HBL-100	BRIXON Latch Kit (older)	

DOOR PULLS

Part No.	Description	
208-252	Handle 5" O/A Zinc	
DH0215	Door Handle Metal	
DH2555	Door Handle Fiberglass	
208-040	Door Pull, Standard Zinc	
208-406	Door Pull (Batch Process Oven)	





HARDWARE

Part No.	Description
KIT-ARLL	Refinish Lever/Latch kit (less rods) Locking Mechanism

PAINT BOOTH DOORS

DOOR SEALS

Part No.	Description	
248-003	.50 x .25 Closed Cell Seal Tape	
248-004	.50 x .50 Closed Cell Seal Tape	
248-007	3/16" x 5/8" W, 30' Roll Butyl Tape	
248-011	.125 x 3.0 W Rubber Strip	
248-012	.125 x 4.0 W Rubber Strip	
248-013	.125 x 5.0 W Rubber Strip	
248-014	.125 x 6.0 W Rubber Strip	
248-021	.125 x 8.0 W Rubber Strip	
248-023	.125 x 10.0 W Rubber Strip	
248-082	P Seal - EPDM Seal Tape (JBI & GFS Industrial Booths)	
248-087	1/4" x 3/4" Wide Open Cell Tape Adhesive	
248-089	1/8" Thick x 5" W Silicone Rubber	
29-1480	12' L x 3" W x 1/8" Door Wiper Seal - Binks	
29-1481	8' L x 2" x 11/16" Bi-Fold Seal Binks	
29-1482	9' L x 2" x 1 1/4" "T" Seal Binks	
29-1484	30' Length - Binks "U" Seal	
KDS	Seal Kit Bi-/Tri-Fold - (2) SS-00748, (3) SS-00749, (1) SS-9688, (1) SS-9874	
SS-00748	15' X 7" x 1/8" Black Rubber S.S. Booths	
SS-00749	12-1/2' x 3/4" x 1-1/2" Foam Tape - S.S. Booths Grey	

Part No.	Description	
SS-00777	.5 X .5 X 25' Roll (LT FXT) Foam Tape	
SS-9688	V Seal 108" Long w/Retainer Strip <i>Tall side: 15/8" Short side: 1 3/8" (tape side)</i>	
SS-9874	34' x 1/4" x 3/8" Black Foam Tape, Single-Skin Booths	
248-035	Tadpole Gasket, .50 Bulb, 1" Tail	



SINGLE-SKIN BOOTHS

Flexbuilt, Semi-Downdraft, Concept II, Concept II Cure, Concept Booths, Old SVS series, Crossdraft, Drive Thru

Part No.	Description
1960 - 1990s	
Solid Back Booths	(3) SS-00748, (3) SS-00749, (1) SS-9874
Drive-Thru Booths	(6) SS-00748, (6) SS-00749, (1) SS-9874
1990s - Present	
Solid Back Booths	(2) SS-00748, (3) SS-00749, (1) SS-9688, (1) SS-9874 (Same as KDS kit)
Drive-Thru Booths	(4) SS-00748, (6) SS-00749, (1) SS-9688, (1) SS-9874

INSULATED BOOTHS

For use on booth panels approximately 2 inches thick. Constructed of two sheets of metal with insulation in between.

Part No.	Description	
39056	3/4" x 3/4" Black rubber hollow strip, frontal and access doors. Blowtherm and Concept Cure.	
R8550	3/4" x 3/4" Black rubber hollow strip, frontal and access doors. GFS Booths.	
DGK-2000	3/4" x 3/4" x 25' Black foam tape. Contains four rolls for re-foaming a 3-door frontal and 1 access door. Older DeVilbiss, System 2000, Expert, Performer and Professional Booths.	

CURTAIN WALLS & DIVIDERS

CURTAIN WALLS & DIVIDERS

Separate and maximize your usable space with Curtain Walls and Dividers from Global Finishing Solutions® (GFS). Safe, cost-effective solutions for confining dirt, dust and contaminants, and controlling cold lost, GFS Curtain Walls are ideal for a wide variety of applications – including aluminum repair, grinding, limited painting, sanding, washing, welding and woodworking. All materials that make up GFS Curtain Walls meet NFPA 701 regulations for fire retardancy.



STEEL-SCRIM™ LAMINATE VINYL



Steel-Scrim Vinyl features a proprietary, tri-lateral polyester scrim design that is 84 percent stronger than standard laminate vinyl.

ROLLER TRACK SYSTEM



The durable, 16-gauge roller track system modularly connects track lengths to your desired shape and length. Select from a beam flange, ceiling, floor or suspended (threaded rod or beam-to-chain) mount.

CHAIN-WEIGHTED HEM



A heavy-duty, 3/15-inch galvanized chain in the bottom pocket of GFS Curtain Walls stabilizes it against drafts.

ELECTRONICALLY WELDED SEAMS



Interior seams are electronically welded with RF bar sealers for an extra-tough resistance to tears. Outer hems are sewn with a heavy-duty, double-lock stitched nylon thread.

ACCESSORIES & OPTIONS

ADHESIVE VELCRO

Attaches any curtain to a brick, metal, concrete or wood wall or door opening.

VINYL FLOOR SWEEP

Seals bottom 1-inch gap to keep dirt, dust and contaminants out. Sewn-in or velcro options are available.

WELD-VIEW WINDOW

14-millimeter, weld-view PVC window blocks harmful UV rays from welding while allowing view of workers, and meets CFM and NFPA 701 standards.

FLOOR MOUNT D-RINGS

Securely fastens curtains to prevent against heavy updrafts. Includes strap and buckle.

BRASS GROMMETS

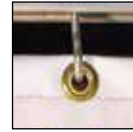

Spaced 12 inches apart, #2 brass-toothed grommets allow curtains to hang securely on roller hooks.

WORK-VIEW WINDOW



A 20-millimeter, flame-resistant and double-polished PVC window allows for a clear view of workers and operations, and meets CFM and NFPA 701 standards.

TWO-WHEEL ROLLER HOOKS



Available with large curtains, two-wheel steel roller hooks make for easy sliding and folding of curtains.

VELCRO ATTACHMENTS



2-inch velcro side attachments connect two curtains together and seal off the area. Available in standard 2-foot swatches, full length or custom.



PAINT BOOTH MOTORS

PAINT BOOTH MOTORS

All AC, polyphase induction motors are mounted on standard NEMA frame bases and are available in explosion-proof and totally enclosed, fan-cooled types. All motors feature ball-bearing construction, heavy-duty, corrosion-resistant housings and bearing brackets.

Rotors and shafts are dynamically balanced to assure smooth, vibration-free operation. Inner races are locked to shaft outer races to end brackets, reducing endplay and maintaining alignment for V-belt drives. Windings are designed for long, dependable life under adverse operating conditions. Integral rotor fans in enclosed types direct cooling air over windings, reducing noise and prolonging motor life. Conduit boxes have ample hand room for easy accessibility and quick connection of leads.

All motors conform to state and local fire and safety regulations and may be mounted in either a vertical or horizontal position. Motors are rated for exhaust fan units at 1750 RPM.

STANDARD

Superior to open drip-type motors, completely enclosed, fan-cooled motors come standard in all GFS products. They are UL approved.



EXPLOSION-PROOF

Featuring a corrosion-resistant epoxy finish, as well as a UL listed conduit box, explosion-proof motors are a safety feature for hazardous locations. They are UL listed for Class I, Group D and Class II, Groups F and G.



HP	Single Phase	Volt	Three Phase	Volt
1/3	MT003-DV1-0056	Dual	MT003-573-0056	575
			MT003-TV3-0056	Tri
1/2	MT005-DV1-0056	Dual	MT005-573-0056	575
			MT005-TV3-0056	Tri
3/4	MT007-DV1-0056	Dual	MT007-573-0056	575
			MT007-TV3-0056	Tri
1	MT010-DV1-0056	Dual	MT010-573-0056	575
			MT010-TV3-0056	Tri
			MT010-TV3-143T	Tri
2	MT020-DV1-145T	Dual	MT020-TV3-145T	Tri
			MT020-573-145T	575
3	MT030-DV1-184T	Dual	MT030-573-182T	575
			MT030-TV3-182T	Tri
5	MT050-231-184T	230	MT050-573-184T	575
			MT050-TV3-184T	Tri
			MT075-203-213T	200
7 1/2	MT075-231-215T	230	MT075-573-213T	575
			MT075-TV3-213T	Tri
			MT100-203-215T	200
10	Contact GFS		MT100-573-215T	575
			MT100-TV3-215T	Tri

HP	Single Phase	Volt	Three Phase	Volt
1/3	MX003-TV1-0056	Tri	MX003-TV3-0056	Tri
			MX003-573-0056	575
1/2	MX005-DV1-0056	Dual	MX005-573-0056	575
			MX005-TV3-0056	Tri
3/4	MX007-DV1-0056	Dual	MX007-573-0056	575
			MX007-TV3-0056	Tri
1	MX010-DV1-0056	Dual	MX010-573-0056	575
			MX010-TV3-0056	Tri
2	MX020-DV1-182T	Dual	MX020-573-145T	575
			MX020-TV3-145T	Tri
3	Contact GFS		MX030-573-182T	575
			MX030-TV3-182T	Tri
5	Contact GFS		MX050-573-184T	575
			MX050-DV3-184T	Dual
7 1/2	Contact GFS		MX075-573-213T	575
			MX075-TV3-213T	Tri
10	Contact GFS		MX100-573-215T	575
			MX100-DV3-215T	Dual

PAINT BOOTH FANS



TUBE AXIAL EXHAUST FANS (GFA MODELS)

GFA models of GFS' tube axial fans feature continuously welded housing for an airtight seal. The propellers are non-sparking cast aluminum, providing consistent air velocity at higher static pressures. The universal motor plates allow for adjustable belt tensioning. The bearings are of premium air handling quality, self-aligning and have an L10 life of 40,000 hours. The belt guard provides protection from the rotating pulley, per OSHA requirements.

Part No.	A Ring to Ring	B Inside Dim.	C Mounting Bolt	D Outside Dim.
GFA-18	30"	18"	19 1/4"	20 1/2"
GFA-24	30"	24"	25 1/2"	26 7/8"
GFA-30	30"	30"	31 3/4"	33"
GFA-34	30"	34"	35 3/4"	37"
GFA-40	30"	40"	41 3/4"	43"

Note: Sound level data given in the fan chart was obtained under laboratory conditions. It is not likely that these results will permit determination of sound power in all site conditions.

Data published in this chart may be used for the following purposes:

- Comparison of fans that are similar in type and size.
- Scaling down fan noise from one size and speed to another size and speed.

Depending on the application, configuration of the apr duct, attention characteristics of material used, and acoustical condition, etc., the reduction in dB will vary.

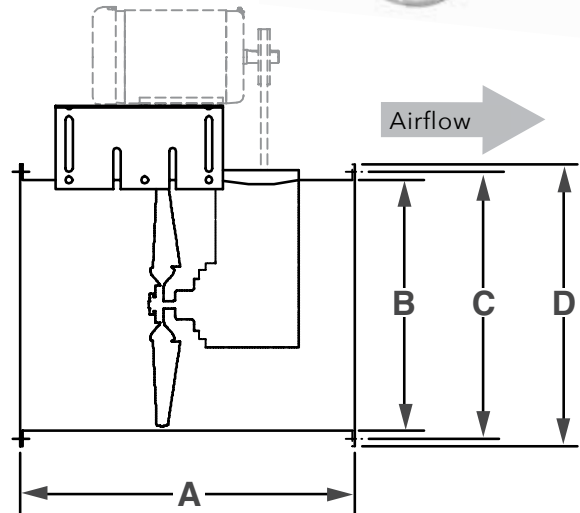

Model No. (Less Motor)	HP	RPM	Free Air	0.25"	0.375"	0.5"	0.75"	1.0"	1.25"	dBa
18" Tube Axial Fan										
GFA-18VP-003	1/3	1228-1332	2610-2831	1304-1608	--	--	--	--	--	72 - 74
GFA-18VP-005	1/2	1437-1541	3054-3275	1940-2282	1430-1703	--	--	--	--	76 - 78
GFA-18VP-007	3/4	1437-1854	3054-3941	1940-3326	1430-2686	1618*-2187	--	--	--	76 - 82
GFA-18VP-010	1	1593-2116	3386-4498	2461-4081	1857-3570	1748*-3021	1700*-2231	--	--	78 - 85
GFA-18VP-020	2	2116-2638	4498-5607	4081-5273	3570-5106	3021-4754	2231-3851	2833*-3140	--	85 - 90
24" Tube Axial Fan										
GFA-24VP-010	1	1437-1541	5691-6102	5142-5610	4796-5288	4353-4966	3866*	--	--	82 - 84
GFA-24VP-020	2	1593-2011	6308-7964	5842-7669	5531-7422	5334-7175	4225-6681	4621*-6019	4294*-5141	85 - 90
GFA-24VP-030	3	1802-2220	7136-8791	6763-8550	6487-8340	6212-8116	5601-7669	4621-7221	4294*-6545	88 - 93
30" Tube Axial Fan										
GFA-30VP-020	2	610-835	7618-10582	5571-9363	4150-8596	5427*-7579	--	--	--	77 - 84
GFA-30VP-030	3	700-926	8804-11760	7217-10828	5979-10078	5427*-9377	6959*	--	--	80 - 86
GFA-30VP-050	5	971-1197	12379-15357	11469-14617	10810-14211	10131-13725	8322-12615	7898*-11349	8345*-9377	87 - 92
34" Tube Axial Fan										
GFA-34VP-020	2	915-1108	11978-14504	10164-13265	8740-12232	9851*-11063	--	--	--	84 - 87
GFA-34VP-030	3	979-1236	12816-16180	11248-15069	9943-14392	9851*-13373	11076*	--	--	86 - 92
GFA-34VP-050	5	1108-1429	14504-18706	13265-17746	12232-17265	11063-16649	11076*-14878	12835*	--	89 - 95
40" Tube Axial Fan										
GFA-40VP-050	5	915-1140	21163-26367	18374-24197	16364-23032	13626-21693	15746*-17392	--	--	87 - 93
GFA-40VP-075	7 1/2	937-1242	21672-28726	18974-26734	17189-25738	14424-24553	1665*-21157	--	--	88 - 95

Premium efficient replacement motors, may vary in physical size from Standard efficient motors.

dBa is only an estimate of sound pressure at 5 ft.

* - This represents the lowest possible CFM at a particular static pressure due to instability of the fan curve.

The drive sheave cannot be set below a certain RPM for the ratings.

PAINT BOOTH FANS

TUBE AXIAL EXHAUST FANS (ATA MODELS)

GFS' tube axial fans are the ideal choice for installations with straight-through airflow in ducted or non-ducted systems. The tube axial fans are designed for commercial and industrial applications in which low to medium air volumes are required at lower pressures. Units come pre-assembled and include variable-pitch motor sheaves for maximum operating efficiency and on-site adjustment.



Part No.	A Inside Dim.	B Mounting Bolt	C Outside Dim.	D Ring to Ring
ATA-12	12.25	13.50	14.88	18.00
ATA-18	18.25	19.50	21.00	18.00
ATA-24	24.25	25.50	27.13	19.50
ATA-30	30.38	32.00	33.25	22.00
ATA-36	36.38	38.00	39.38	22.00
ATA-42	42.40	44.00	45.50	22.00
ATA-48	48.50	50.00	51.50	24.00

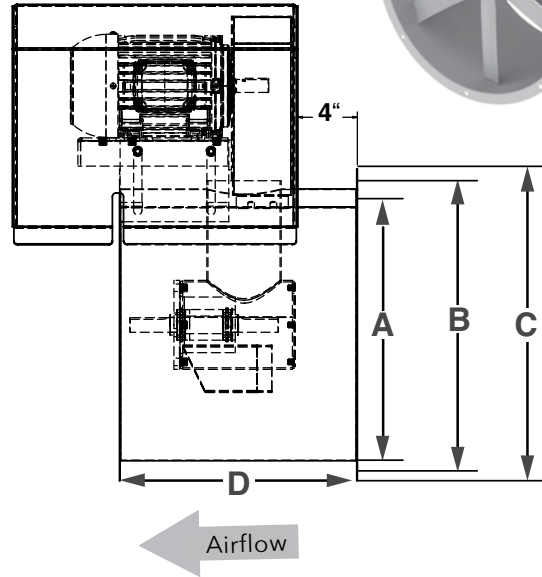

Performance shown is for installation type B: free inlet, ducted outlet. Power rating (BHP) does not include drive losses. Performance ratings do not include the effects of appurtenances in the airstream. This product is certified to bear the AMCA seal for air performance.

Sound pressure range listed is A-weighted at a distance of 5 feet from the fan with a directivity factor of Q=2 (hemispherical radiation) and has been tested per AMCA standard 303. The range covers the minimum and maximum air performance points shown. Lowest sound pressure level is for the lowest airflow rate (CFM) at the lowest static pressure (SP). Highest sound pressure level is for the highest airflow rate (CFM) at the highest static pressure (SP).

Model #	HP	Fan Speed Range		Static Pressure Rating (in. w.c.)							dBA 5ft, Q=2	
		Min	Max	Free Air	0.25	0.375	0.5	0.75	1	1.25		1.5
12" Tube Axial												
ATA-12-007	w 3/4	2043	3016	1355 - 1985	1180 - 1885	1075 - 1830	950 - 1770	960 - 1630	1145* - 1460	1085* - 1245	--	65-76
18" Tube Axial												
ATA-18-005	1/2	1112	1641	2530 - 3740	1835 - 3325	1715 - 3090	2085 - 2800	--	--	--	--	58-68
ATA-18-007	3/4	1260	1860	2875 - 4241	2290 - 3890	1900 - 3685	2135 - 3460	2505* - 2965	--	--	--	61-72
ATA-18-010	1	1600	2100	3630 - 4780	3225 - 4480	2974 - 4311	2690 - 4130	2600* - 3730	3260*	--	--	67-73
ATA-18-020	2	2015	2545	4585 - 9800	4270 - 5550	4090 - 5420	3900 - 5280	3480 - 4985	2930 - 4660	3650* - 4300	3895*	72-79
24" Tube Axial												
ATA-24-020	2	1182	1561	6590 - 8725	5630 - 8040	5035 - 7645	4280 - 7215	5270* - 6250	--	--	--	66-75
ATA-24-030	3	1543	1971	8650 - 11040	7930 - 10495	7525 - 10205	7085 - 9900	6095 - 9240	6035* - 8525	6905* - 7700	--	72-80
30" Tube Axial												
ATA-30-030	3	1077	1413	10925 - 14360	9650 - 13430	8860 - 12910	7960 - 12340	7800* - 11080	8400* - 9500	--	--	70-84
ATA-30-050	5	1358	1672	13800 - 17005	12830 - 16235	12270 - 15810	11670 - 15365	10320 - 14400	8500 - 13340	10000* - 12115	10580*	75-88
36" Tube Axial												
ATA-36-050	5	1116	1370	18160 - 22320	16495 - 21000	15500 - 20260	14430 - 19470	11890 - 17740	12700* - 15790	13460*	--	72-81
ATA-36-075	7 1/2	1228	1541	19995 - 25120	18500 - 23960	17650 - 23320	16710 - 22650	14660 - 21200	12110 - 19625	14525* - 17875	15810*	77-83
42" Tube Axial												
ATA-42-075	7 1/2	1096	1349	25445 - 31345	23765 - 30015	22780 - 28500	21700 - 28490	19310 - 26760	16060 - 24870	16650* - 22680	19970*	75-87
ATA-42-100	10	1158	1454	26890 - 33790	25315 - 32570	24410 - 31890	23415 - 31185	21230 - 29650	18545 - 27955	16650* - 26150	18850* - 22400	77-86
48" Tube Axial												
ATA-48-100	10	820	1009	32770 - 40371	29790 - 38031	27980 - 36695	26020 - 35255	21660 - 32110	22000* - 29100	24760*	--	81-86

* - This represents the lowest possible CFM at a particular static pressure due to instability of the fan curve. The drive sheave cannot be set below a certain RPM for the ratings.

PAINT BOOTH FANS & LIGHTING

HIGH-PERFORMANCE VANE AXIAL FANS

High-performance vane axial fans are designed for moving air through systems with resistance up to 4 inches of water gauge loss. Vane axial fans feature a propeller with a large hub and short, wide, airfoil blades. In addition, a set of guide vanes is installed in the fan housing to straighten the rotation of the air stream created by the propeller. This combination of propeller design and guide vanes allows the fan to produce higher pressures and greater efficiencies. At lower static pressures, the vane axial fan will move large air volumes at lower speeds.



MIXED-FLOW INLINE EXHAUST FANS

Mixed-flow inline fans can be used with clean air for supply, exhaust or return air installations. These fans are designed to excel in commercial applications in which low sound is critical. These models are more efficient than comparably sized tubular centrifugal and vane axial fans, reducing the required motor horsepower and lowering operating costs. Contact GFS for specific performance data.



PAINT BOOTH LIGHTING

For an exceptional spray environment, GFS has a full line of light fixtures – LED, fluorescent, incandescent and explosion-proof. GFS also offers a full line of replacement light fixtures, bulbs and parts for all makes and models of finishing equipment, including paint booths, dust collection booths and blast booths.

T8 LIGHT FIXTURES

GFS offers four- or six-tube T8 light fixtures that work interchangeably with high-output fluorescent or LED lamps.

- Energy-efficient, 32-watt electronic ballasts
- ETL and ETL-C listing
- Class I, Division 2, Groups A-D ratings
- Interlock safety switch
- Enclosed and gasketed construction
- Twist-in lamp holders
- Easy lamp replacement and retrofits
- Template for installation into existing panels
- Optional corner enclosures

Part No.	Tube	Length	Lamp Size/Volt/Watt
LABW12-4	4	4'	T8 / 120-277V / 32W
LABW12-6	6	4'	T8 / 120-277V / 32W
LAR12-4	4	4'	T8 / 120-277V / 32W For Dual-Skin Panels
LAR12-6	6	4'	T8 / 120-277V / 32W For Dual-Skin Panels
LAB12-3-36	3	3'	T8 / 120V / 32W For AdvanceCure® Units
LABW12-4-LAM	4	4'	T8 / 120-277V / 32W Blast Booths Only
LABW12-6-LAM	6	4'	T8 / 120-277V / 32W Blast Booths Only
LABW12-4-LED	4	4'	T8 / 120-277V / 32W Lamps Included
LABW12-6-LED	6	4'	T8 / 120-277V / 32W Lamps Included

T5 LIGHT FIXTURES

T5 fluorescent light fixtures and lamps from GFS feature excellent performance and efficiency. GFS offers four- or six-tube inside-access T5 fixtures, designed to fit the smaller diameter of T5 lamps. T5 fixtures and lamps are recommended for enclosures with high ceilings and booths located in areas that reach high temperatures.

- Environmentally responsible when used with low-mercury lamps
- Class I, Division 2, Groups A-D ratings
- Enclosed and gasketed construction
- Interlock safety switch
- Easy lamp replacement and retrofits
- 54-watt ballasts



Part No.	Tube	Length	Lamp Size/Volt/Watt
LABW-14T5-D12	4	4'	T5 / 120-277V / 54W
LABW-16T5-D12	6	4'	T5 / 120-277V / 54W

REPLACEMENT LAMPS

Part No.	Length	Replacement for:
230-281	4'	T8 fixtures, 32W
230-285	4'	T5 fixtures, 54W
230-271	3'	LAB12 fixtures, 32W



CLASS II, DIVISION 2 FIXTURES

Part No.	Tube	Length	Lamp Size/Volt/Watt
LAB12-4-C2D2	4	4'	T8 / 120-277V / 32W
LAB12-6-C2D2	6	4'	T8 / 120-277V / 32W

PAINT BOOTH LIGHTING

T8 LED LAMPS

T8 LED lamps are an ideal energy-saving choice for existing linear fluorescent light fixtures. Upgrade to LED easily without having to change the fixture. LED lamps are compatible with GFS' linear light fixtures, including inside access and corner paint booth light fixtures, and general purpose light fixtures.



Part No.	Description
230-286A	T8 4' LED instant fit lamp
230-288	T8 3' LED instant fit lamp (AdvanceCure® towers)

LIGHT SEALS

Part No.	Description
248-126	Seals glass to frame
GFT5108	Seals light fixture to housing

EXPLOSION-PROOF LIGHTING

Explosion-proof lighting is recommended for hazardous locations, such as paint booths, shipyards, chemical manufacturers, oil drilling rigs and gas processing plants. Made with factory sealed, cased aluminum and a white finish reflector.



- UL listed for use in paint booths and mix rooms
- UL 844 listed for hazardous locations
- UL 595 listed for outdoor, marine-type lighting (salt water)
- Class I, Division 1, Groups C & D ratings
- Class I, Division 2, Groups A-D ratings
- Class II, Divisions 1 and 2, Groups E-G ratings
- Meets requirements for NFPA 33 and NEC Article 516

Part No.	Tube	Length	Lamp Size/Volt/Watt
230-163	4	4'	T8 / 120-277V/60W
230-163	2	4'	T8 / 120-277V/60W

FLUORESCENT LIGHTING

Part No.	Tube	Length	Lamp Size/Volt/Watt
230-306	2	4'	T8 / 120V / 32W
230-501	4	4'	T8 / 120-277V / 32W
230-400	2	3'	T8 / 120V / 25W
230-405	4	3'	T8 / 120V / 25W
230-551	4	4'	120V / 32W

CORNER LIGHT FIXTURES

Part No.	Tube	Length	Lamp Size/Volt/Watt
LAC12-4	4	4'	T8 / 120-277V / 32W
LAC12-6	6	4'	T8 / 120-277V / 32W



HIGH BAY FLUORESCENT LIGHTS

High bay fluorescent lights are specifically designed for general purpose applications and meant to replace metal-halide lighting and T12 light fixtures to improve energy efficiency. GFS high bay lights are ideal for structures such as warehouses, commercial buildings and gymnasiums.

- T5 or T8 lamps
- Six-tube fixtures
- Energy efficient



Part No.	Tube	Length	Lamp Size/Volt/Watt
LFG-1749-6	6	4'	T5 / 120-277V / 54W
LFG-1749-6-T5	6	4'	T5 / 120-277V / 54W

Part No.	High Bay Accessories	Description
LFGA-PC120-10-KIT	120V, 10'	power cable
LFGA-PC277-10-KIT	277V, 10'	power cable
LFGA-SC-10	10'	suspension cable
LFGA-VH	V-Hanger	bracket
LFGA-WG1648	16.5" x 48"	wire guard
LFGR-003	Standard Reflector	- Wide light distribution
LFGR-007	Deep Well Reflector	- Narrow light distribution

Additional lengths are available

INCANDESCENT FIXTURES

Incandescent fixtures are recommended for use in mix rooms and hazardous materials storage rooms. Angle fixtures can be supported for mounting at the face of a paint booth with a fixture bracket. Incandescent fixtures are Class I, Division 1 listed.



Part No.	Description	
600-001	Ceiling Mount with Dome	150/300W
600-002	Wall Mount with Dome	150/300W
600-006	Ceiling Mount with Angle	150/300W

LIGHT BOOSTING REFLECTOR

Increase the luminosity of your paint booth with this simple upgrade, available for GFS four- or six-tube light fixtures. GFS' unique reflector shape and material focuses more light where you need it, more efficiently directing light toward the working area of your paint booth. Light reflectors can easily be installed behind fluorescent light tubes, boosting the luminosity of fixtures by 20 percent. You can achieve the same level of luminosity with fewer bulbs than our competitors, saving energy and maintenance costs.

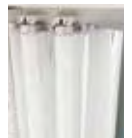

Part No.	Description
LR-48-4	Light reflector for LABW12-4 and LAB12-4
LR-48-6	Light reflector for LABW12-6 and LAB12-6

REPLACEMENT GLASS

Part No.	Replacement for:
GF-4	Standard four-tube light fixtures
GF-6	Standard six-tube light fixtures

PAINT BOOTH DUCTWORK

ROOF FLANGES

GFS recommends a custom curb on a roof pitch that exceeds 4-by-12 inches. Roof flanges are not recommended for corrugated metal roofs.

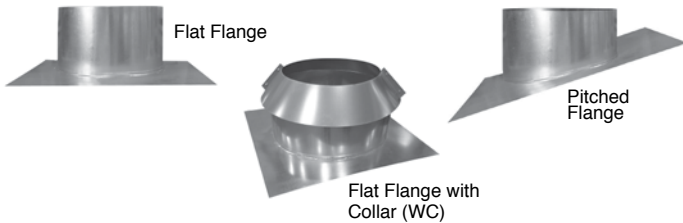

Part No.	Part No.	Diameter
Flat	Pitched	
DU-FRF-10-WC	DU-PRF-10-__-WC	10"
DU-FRF-12-WC	DU-PRF-12-__-WC	12"
DU-FRF-18-WC	DU-PRF-18-__-WC	18"
DU-FRF-24-WC	DU-PRF-24-__-WC	24"
DU-FRF-30-WC	DU-PRF-30-__-WC	30"
DU-FRF-34-WC	DU-PRF-34-__-WC	34"
DU-FRF-36-WC	DU-PRF-36-__-WC	36"
DU-FRF-40-WC	DU-PRF-40-__-WC	40"
DU-FRF-42-WC	DU-PRF-42-__-WC	42"
DU-FRF-48-WC	DU-PRF-48-__-WC	48"

ELBOWS

Elbows with full-radius throat and pipe diameter design allow for a smooth interior surface. With minimized airflow resistance, turbulence and exhaust air noise management, elbows are superior and can be utilized in most applications. All sizes are constructed from galvanized steel and may require connector rings on each end (sold separately).



Part No.	Part No.	Diameter
45 degrees	90 degrees	
DU-E45M-10	DU-E90M-10	10"
DU-E45M-12	DU-E90M-12	12"
DU-E45M-18	DU-E90M-18	18"
DU-E45M-24	DU-E90M-24	24"
DU-E45M-30	DU-E90M-30	30"
DU-E45M-34	DU-E90M-34	34"
DU-E45M-36	DU-E90M-36	36"
DU-E45M-40	DU-E90M-40	40"
DU-E45M-42	DU-E90M-42	42"
DU-E45M-48	DU-E90M-48	48"

ACCESS DOORS

An access door is a removable door for inspecting and cleaning ductwork and exhaust fans. The access door price is not included in the duct price, unless indicated.



Part No.	Diameter
DU-SDD-1212	12"
DU-SDD-1718	17" to 18"
DU-SDD-2224	22" to 24"
DU-SDD-2932	29" to 32"
DU-SDD-3336	33" to 36"
DU-SDD-3740	37" to 40"
DU-SDD-4144	41" to 44"
DU-SDD-4548	45" to 48"
DU-FDD-1612	12" x 16" For Flat Ductwork

GUY WIRE KIT

A guy wire kit includes 50 feet of 1/8-inch cable, anchors, turnbuckles and clamps for the installation of three guy wires to an exhaust stack. Connector rings are sold separately.

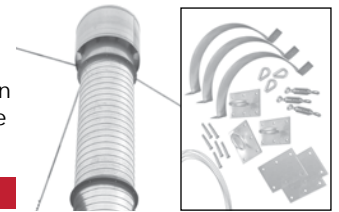

Part No.	Diameter
DU-GWK-10	10"
DU-GWK-12	12"
DU-GWK-18	18"
DU-GWK-24	24"
DU-GWK-30	30"
DU-GWK-34	34"
DU-GWK-36	36"
DU-GWK-40	40"
DU-GWK-42	42"
DU-GWK-48	48"



PAINT BOOTH DUCTWORK

ROOF VENTILATOR

The roof ventilator provides protection against rain, snow and backdrafts for the exhaust system, paint booth and operator. All sizes are constructed from galvanized steel. Requires some assembly and may require connector rings (sold separately).



Part No.	Diameter
DU-ARV-10	10"
DU-ARV-12	12"
DU-ARV-18	18"
DU-ARV-24	24"
DU-ARV-30	30"
DU-ARV-34	34"
DU-ARV-36	36"
DU-ARV-40	40"
DU-ARV-42	42"
DU-ARV-48	48"

EXHAUST DUCT

An exhaust duct comes with a straight, 3-foot-long section, with one end corrugated for easy installation. All sizes are constructed from galvanized steel and require some assembly.



Part No.	Diameter
DU-PLP-10-3	10"
DU-PLP-12-3	12"
DU-PLP-18-3	18"
DU-PLP-24-3	24"
DU-PLP-30-3	30"
DU-PLP-34-3	34"
DU-PLP-36-3	36"
DU-PLP-40-3	40"
DU-PLP-42-3	42"
DU-PLP-48-3	48"



SPIRAL DUCT

Sold by the foot, spiral ducts are available in 2- to 8-foot lengths. All sizes are constructed from galvanized steel and require connector rings on each end (sold separately).



Part No.	Diameter
DU-SPP-10	10"
DU-SPP-12	12"
DU-SPP-18	18"
DU-SPP-24	24"
DU-SPP-30	30"
DU-SPP-34	34"
DU-SPP-36	36"
DU-SPP-40	40"
DU-SPP-42	42"
DU-SPP-48	48"

EXHAUST STACK KITS

Exhaust stack kits include three 3-foot plain exhaust duct sections, one 3-foot universal stack with access door and one roof ventilator.



Part No.	Diameter
DU-STK-10	10"
DU-STK-12	12"
DU-STK-18	18"
DU-STK-24	24"
DU-STK-30	30"
DU-STK-34	34"
DU-STK-36	36"
DU-STK-40	40"
DU-STK-42	42"

CONNECTOR RINGS

Connector rings are used for connecting an exhaust fan to other exhaust system stack components. One connector ring is supplied with fan assemblies.



Part No.	Diameter
409-110	10"
409-112	12"
409-118	18"
409-124	24"
409-130	30"
409-134	34"
409-136	36"
409-140	40"
409-142	42"
409-148	48"

PAINT BOOTH ELECTRICAL COMPONENTS

AIR PROVING SWITCH

An air proving switch is an automatic pressure switch that measures air pressure at the exhaust chamber. It is recommended for use with a safety air valve.

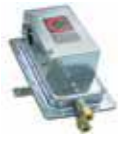

Part No.
242-004

SAFETY AIR VALVE

A three-port, two-position safety air valve prevents spraying with air assist systems when booth exhaust is off. Compressed air between the valve and spray equipment is vented out when the exhaust is shut off. It features a 120-volt coil.

Part No.	Size
242-019	1/2"
242-124	3/4"



SPRAY GUN INTERLOCK

The spray gun interlock controls the paint booth function from paint mode to energy-saving mode, based on airflow from the spray gun.



Part No.
36267

SAFETY SHUT-DOWN

Simplify your test panel process with a safety shutdown. Simply attach paper or metal test panels, then hold and spray. For flash and dry times or everyday storage, place the Test Panel Holder™ on the wall of a paint booth – or other sheet metal surface – by its magnets.



Part No.	Description
600-003	Standard System
600-004	Standard System with Audible Alarm
600-005	Explosion-Proof System

GUN HANGER SWITCH

An energy-saving feature, the gun hanger switch triggers the VFD to slow down the fan when the spray gun is placed on the hook, and return the fan to full speed when it is removed from the hook. The GunHanger is explosion-proof, and is Class I, Division 2 listed.



Part No.
600-035

MAGNEHELIC GAUGE

A magnahelic gauge indicates when the cabin of a paint booth is balanced and ready for spraying. The gauge must be calibrated prior to use.



Part No.
GA-9706

MANOMETER/DRAFT GAUGE

A manometer measures static pressure resistance, indicating when paint arrestors or air intake filters are sufficiently loaded and need replacement. Manometers are included with all GFS exhaust chambers and paint booths.



Part No.
242-001



PAINT BOOTH ELECTRICAL COMPONENTS

EXPLOSION-PROOF START/STOP

An explosion-proof start/stop is to be used with motor starters. It is a heavy-duty, front-operated button that can be mounted directly onto a paint booth.

Part No.
127-221



GENERAL PURPOSE START/STOP

A general purpose start/stop is to be used with motor starters. NEMA Type 1 with NO-NC contacts, it must be mounted in a non-hazardous location.

Part No.
127-219



PNEUMATIC START/STOP

A pneumatic start/stop activates a pneumatic-electric interface, turning an exhaust fan on and off. A non-sparking pneumatic switch is located inside a paint booth, allowing the operator to enter and leave the booth with the exhaust fan turned off and preventing dirty, unfiltered air from entering the paint area.

Part No.
650-003



EXPLOSION-PROOF LIGHT SWITCH

An explosion-proof light switch is to be used with lights in hazardous locations. With a front-operated on/off switch, it is capable of handling a 1400W-AC power supply.

Part No.
650-001



GENERAL PURPOSE LIGHT SWITCH

A general purpose light switch is to be used with lights in non-hazardous locations. With an on/off switch, it is capable of handling a 1400W-AC power supply.

Part No.
650-002



EXPLOSION-PROOF LIMIT SWITCH

An explosion-proof limit switch is an electronically operated switch that shuts down painting operations when a paint booth's doors are opened, designed for environments with a risk of explosion or fire from sparks. The explosion-proof limit switch is Class I, Division 1 listed.

Part No.
242-012



STANDARD LIMIT SWITCH

A standard limit switch is an electronically operated switch that shuts down painting operations when a paint booth's doors are opened, designed for general use applications. The standard limit switch is Class I, Division 2 listed.

Part No.
242-014A



ROLL-UP DOOR SWITCH

Part No.
127-260
127-266



PAINT BOOTH PROTECTION



BOOTH SHIELD®

Whether you want to protect your paint booth's walls, windows, lights or floor, the Booth Shield line from GFS has the right product for you. Booth Shield provides superior protection and creates a safer spraying environment. Coatings can be applied quickly and removed easily, without damaging the underlying substrate.

BRIGHTEN & PROTECT

Booth Shield offers outstanding coverage to protect your investment. Coatings are easier to use than traditional paper wrap, with significantly less mess. Once dry, floor and wall coatings stand up to heavy use, including foot and vehicle traffic. Booth Shield Peelable White for walls and floors brightens galvanized booths, giving them a clean white finish and ensuring prime visibility for working inside the booth.

EASY APPLICATION

Booth Shield provides the flexibility to spray or roll the coating onto your surface and build to the thickness you need. Most wall applications are complete after only one coat, and floor coatings can withstand heavy-duty traffic after just two layers. Booth Shield dries quickly, so you can resume full use of your booth within hours of application. If a booth surface is damaged, prep coats are available to ensure smooth application and release.

FAST REMOVAL

When it is time to remove and replace the booth coating, simply score the edges and peel Booth Shield off your surface. The durable film can be removed in large sections from walls, ceilings, lights and floors, saving time and creating less mess. Once the coating is removed, it can be compressed to consolidate waste and disposed of normally.

COAT ANY PAINT BOOTH SURFACE

Choose from a complete line of Booth Shield products to meet your booth's needs. With minimal cleanup and surface preparation required before application, GFS offers the following Booth Shield products:

- Wall and Floor Prep (water-based)
- Peelable White for Galvanized Booths (water- or solvent-based)
- Peelable Translucent for White Pre-Coated Booths (water-based)
- Peelable White Floor Coat (solvent-based)

Part No.	Description
236-062	Floor Prep Water Based - 1 gal, 315 sq. ft.
236-066	Peelable White Solvent Based Floor - 1 gal, 25 sq. ft.
236-067	Wall Prep Water Based - 1 gal, 385 sq. ft.
236-065	Peelable White Water Based Wall - 1 gal, 75 sq. ft.
236-068	Translucent Water Based - 1 gal, 165 sq. ft.
236-063-5PL	Peelable White Solvent Based Floor - 5 gal, 125 sq. ft.
236-061-5PL	Wall Prep Water Based - 5 gal, 1,925 sq. ft.
236-064-5PL	Peelable White Water Based Wall - 5 gal, 385 sq. ft.
236-039-5PL	Translucent Water Based - 5 gal, 835 sq. ft.
236-041-5PL	Peelable White Solvent Based Floor - 5 gal, 225 sq. ft.
236-063-55DM	Peelable White Solvent Based Floor - 55 gal, 1,375 sq. ft.
236-064-55DM	Peelable White Water Based Wall - 55 gal, 4,235 sq. ft.

BOOTH PAPER

Booth Paper from GFS provides a clean, easily replaceable, fire-retardant lining for your paint booth's walls and floors.



Rolls of Booth Paper are available in varying widths to efficiently cover your booth and protect the surface from paint and contaminant buildup, while the exposed surface prevents the migration of dust and overspray.

Part No.	Description
217-081	36" x 300' roll
217-083	60" x 300' roll
217-084	72" x 300' roll

LIGHT FIXTURE LENS PROTECTOR

Protect your light fixtures from overspray and darkening with Light Fixture Lens Protectors from Global Finishing Solutions.



This clear, cling-on plastic film has a 2-millimeter thickness and is easy to apply and replace. Rolls are available in three widths and provide a crystal-clear protective coating, again and again.

Part No.	Description
230-004	18" x 100' roll
230-210	12" x 100' roll
230-211	Dispenser

DIRT TRACK MATS

Prevent contaminants from entering your paint booth with DirtTrack mats from GFS. Position the multi-layered, adhesive mat in front of product or personnel doors to trap dirt and dust from shoes or tires.



Once a sheet becomes soiled, it simply can be peeled off and discarded, leaving a fresh mat in its place.

Part No.	Description
217-240	24" x 30"
217-241	36" x 60"

globalfinishing.com

800-848-8738 • parts@globalfinishing.com

© 2019 Global Finishing Solutions®. All Rights Reserved. Rev.021720



**GLOBAL
FINISHING
SOLUTIONS**